

Ministerial Order no. 556/05.06.2006 on specific marking applied on electric and electronic equipment put on the market after 31st December 2006

In accordance with the provisions of art. 11 paragraph (4) and (5) from the Government Decision no. 448/2005 on WEEE, art. 5 paragraph (8) from the Government Decision no 408/2004 on the organization and functioning of the Ministry of Environment and Water Management, with subsequent changes and completions, the Governmental Decision no. 738/2003 on the organization and functioning of the Ministry of Economy and Trade with subsequent changes and the Governmental Decision no. 755/2003 on the organization and functioning of the Consumer Protection National Authority with subsequent changes,

the minister of environment and water management, the ministry of economy and trade and the president of Consumer Protection National Authority issue the following order :

Art. 1

(1) The EEE put on the market after 31st of December 2006 shall be labelled as per the label format included in annex 1 herein.

(2) If size of the product or the functionality means that the marking cannot be applied on the product, the respective label shall be applied on the packaging, on the operating instructions and on the warranty certificate of the product or special label attached of the EEE.

Art. 2

(1) Any producers who put on the market EEE after 31st December 2006 is in force to be identified through a label (market) with data of identifications: name of the producer, the registration number from Commerce Register National Office (CUI) or any informations of producer identification, another than similar label applied before

(2) The „producer” definition is provide at the art.3 letter i) from the Governmental Decision no. [448/2005](#) on WEEE.

Art. 3

The failing of the labels and marks shall constitute offences and shall be penalized in accordance with the provisions of art.13 paragraph (1) letter c) from GD no. [448/2005](#) on WEEE.

Art. 4

The present order shall be published in the Official Journal of Romania, Part I.

ANEXĂ:

A. Design of the marks



Varianta I



Varianta II

B. Dimensional relationship of the marks

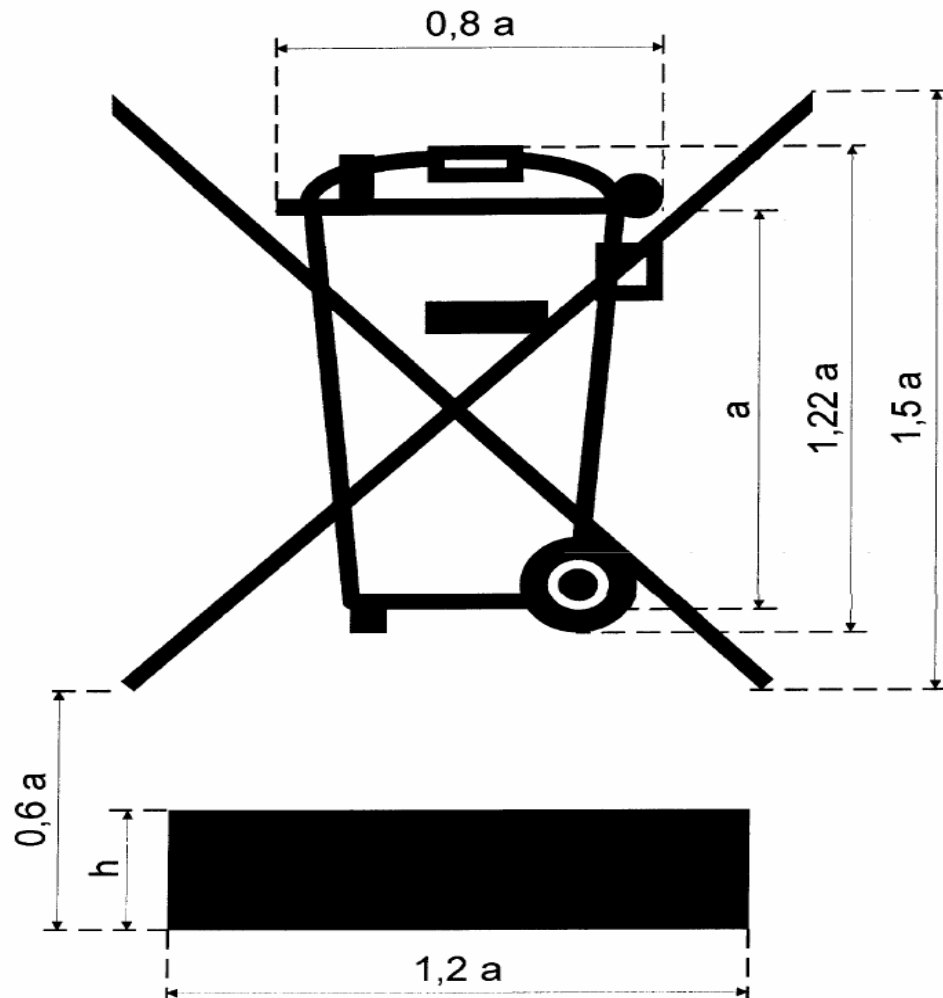

The mark indicates the fact that the products are put on the market after 31st of December 2006.

The symbol should be printed accessible, legible and durable.

The mark consists of a solid bar, the height of which equals „h” and the width of which shall be greater of $0,3a$ or 1 mm, where „a” represents the height of the bin.

The solid bar should be use only together with the crossed-out wheeled bin and shall not contain any kind of information or images.

The mark should comply with the dimensional relationship shown in the Figure.

The MO is published in the Official Journal of Romania, no. 608 from July 13, 2006